

### Product Summary

The GPL6205 series are a group of positive voltage regulators manufactured by CMOS technologies with high ripple rejection, ultra-low noise, low power consumption and low dropout voltage, which can prolong battery life in portable electronics. The GPL6205 series work with low-ESR ceramic capacitors, reducing the amount of board space necessary for power applications. The GPL6205 series consume less than 0.1 $\mu$ A in shutdown mode and have fast turn-on time less than 50 $\mu$ S. The series are very suitable for the battery-powered equipments, such as RF applications and other systems requiring a quiet voltage source.

### Features

- Low Quiescent Current: 50 $\mu$ A
- Low Output Noise: 40 $\mu$ V<sub>RMS</sub>(10Hz~100kHz)
- Operating Voltage Range: 2.0V~6.0V
- Low Dropout Voltage: 150mV@150mA
- Output Voltage: 1.2~ 5.0V
- High Accuracy:  $\pm 2\%$ / $\pm 1\%$ (Typ.)
- TTL-Logic-Controlled Shutdown Input
- Excellent Line and Load Transient Response
- Built-in Current Limiter, Short-Circuit Protection

### Applications

- Cellular and Smart Phones
- Radio control systems
- Laptop, Palmtops and PDAs
- Digital Still and Video Cameras
- Battery-Powered Equipment

### Block Diagram

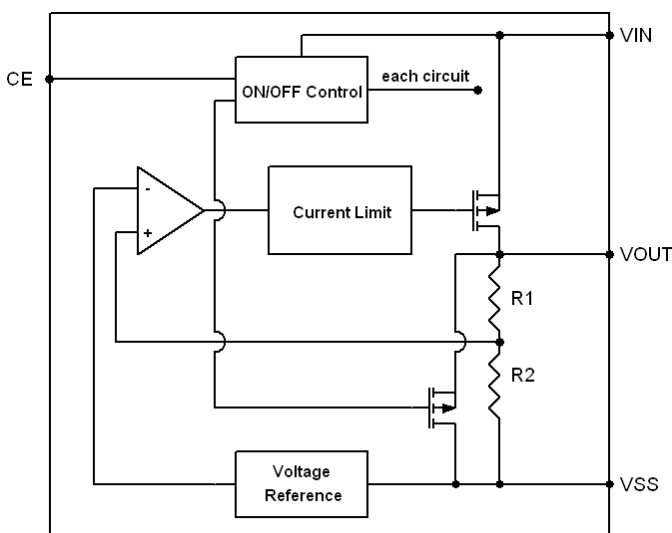

### Order Information

GPL6205V①②

Designator	Description
①	Output Voltage e.g. 1.8V=18
②	Package: SOT-23-3L=K3 SOT-23-5L=K5 DFN1*1-4=H1 SOT-89-3L=KE SOT-89-5L=KT

## Pin Configuration

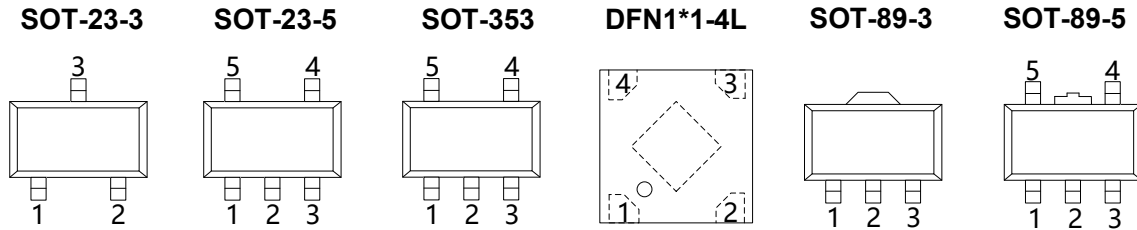

Pin Number		Pin Name	Function
SOT-23-3	SOT-89-3L		
1	1	$V_{SS}$	Ground
2	3	$V_{OUT}$	Output
3	2	$V_{IN}$	Power Input Pin

Pin Number		Pin Name	Function
SOT-23-5L	SOT-353		
1	1	$V_{IN}$	Power Input Pin
2	2	$V_{SS}$	Ground
3	3	CE	Chip Enable Pin
4	4	NC	No Connection
5	5	$V_{OUT}$	Output Pin

### DFN1\*1-4L

Pin Number	Pin Name	Function
1	$V_{OUT}$	Output Pin
2	$V_{SS}$	Ground
3	CE	Chip Enable Pin
4	$V_{IN}$	Power Input Pin

### SOT-89-5L

Pin Number	Pin Name	Function
1	$V_{OUT}$	Output Pin
2	$V_{SS}$	Ground
3	NC	No Connection
4	CE	Chip Enable Pin
5	$V_{IN}$	Power Input Pin

## Absolute Maximum Ratings ( $T_A=25^{\circ}\text{C}$ , unless otherwise noted)

Parameter	Symbol	Ratings	Units	
Input Voltage	$V_{IN}$	$V_{SS}-0.3\sim V_{SS}+7$	V	
Output Voltage	$V_{OUT}$	$V_{SS}-0.3\sim V_{IN}+0.3$	V	
Output Current	$I_{OUT}$	600	mA	
Power Dissipation	SOT-23	$P_D$	0.37	W
	SOT-23-5	$P_D$	0.25	W
	SOT-89/TO-92	$P_D$	0.50	W
	DFN1*1-4	$P_D$	0.40	W
Operating Free Air Temperature Range	$T_A$	-40~85	$^{\circ}\text{C}$	
Operating Junction Temperature Range	$T_j$	-40~125	$^{\circ}\text{C}$	
Storage Temperature	$T_{stg}$	-40~125	$^{\circ}\text{C}$	
Lead Temperature(Soldering, 10 sec)	$T_{solder}$	260	$^{\circ}\text{C}$	
ESD Rating	Human Body Model -(HBM)	$\pm 4$	kV	

## Electrical Characteristics ( $V_{IN}=V_{OUT}+1\text{V}$ , $C_{IN}=C_{OUT}=1\mu\text{F}$ , $T_A=25^{\circ}\text{C}$ , unless otherwise specified)

Parameter	Symbol	Conditions	Min.	Typ.	Max.	Units
Output Voltage	$V_{OUT(E)}^{2)}$	$I_{OUT}=1\text{mA}$	$V_{OUT}*0.98$	$V_{OUT}$	$V_{OUT}*1.02$	V
Supply Current	$I_{SS}$	$I_{OUT}=0$		50	100	$\mu\text{A}$
Standby Current	$I_{STBY}$	$CE = V_{SS}$			0.1	$\mu\text{A}$
Output Current	$I_{OUT}$	—	500			mA
Dropout Voltage <sup>3)</sup>	$V_{dif}$	$I_{OUT} = 150\text{mA}$ $V_{OUT} \geq 2.8\text{V}$		150		mV
Load Regulation	$\Delta V_{OUT}$	$V_{IN} = V_{OUT} + 1\text{V}$ , $1\text{mA} \leq I_{OUT} \leq 100\text{mA}$		10		mV
Line Regulation		$I_{OUT} = 10\text{mA}$ $V_{OUT} + 1\text{V} \leq V_{IN} \leq 6\text{V}$		0.01	0.2	%/V
Output Voltage Temperature Characteristics		$I_{OUT} = 10\text{mA}$ $-40 \leq T \leq +85$		100		ppm
Short Current	$I_{short}$	$V_{OUT} = V_{SS}$		100		mA
Input Voltage	$V_{IN}$	—	2.0		6.0	V
Power Supply Rejection Rate	217Hz	$I_{OUT}=50\text{mA}$		80		dB
	1kHz			75		
	10kHz			70		
CE "High" Voltage	$V_{CE"H"}$		1.5		$V_{IN}$	V
CE "Low" Voltage	$V_{CE"L"}$				0.3	V

- 1)  $V_{OUT}$ : Specified Output Voltage.
- 2)  $V_{OUT(E)}$ : Effective Output Voltage ( i.e. The output voltage when  $V_{IN} = (V_{OUT} + 1.0\text{V})$  and maintain a certain  $I_{OUT}$  Value).
- 3)  $V_{dif}$ : The Difference Of Output Voltage And Input Voltage When Input Voltage Is Decreased Gradually Till Output Voltage Equals To 98% Of  $V_{OUT}$  (E).

## Dropout Voltage Chart

Setting Output Voltage $V_{OUT}(V)$	Dropout Voltage(mV)@ $I_{OUT}=150mA$	
	Typ.	Max.
1.5	270	600
1.8	230	600
2.5	180	400
2.8	160	220
3.0	155	220
3.3	150	220

## Typical Application

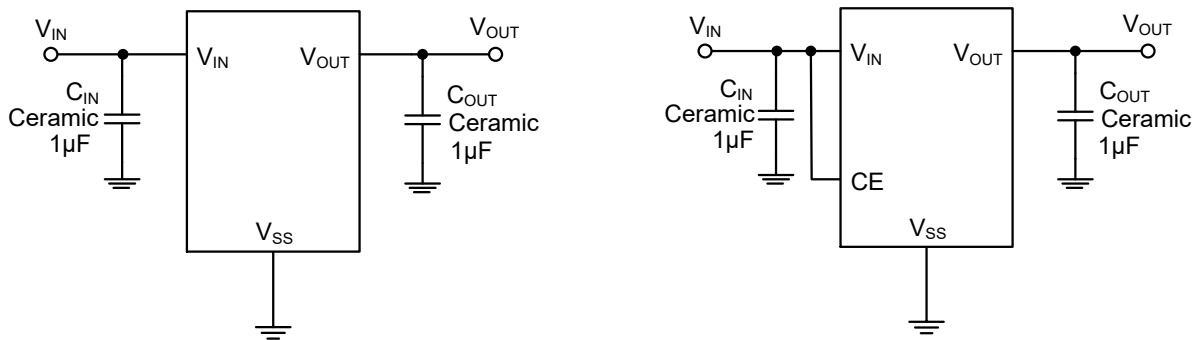

## Typical Performance Characteristics

### Output Characteristics

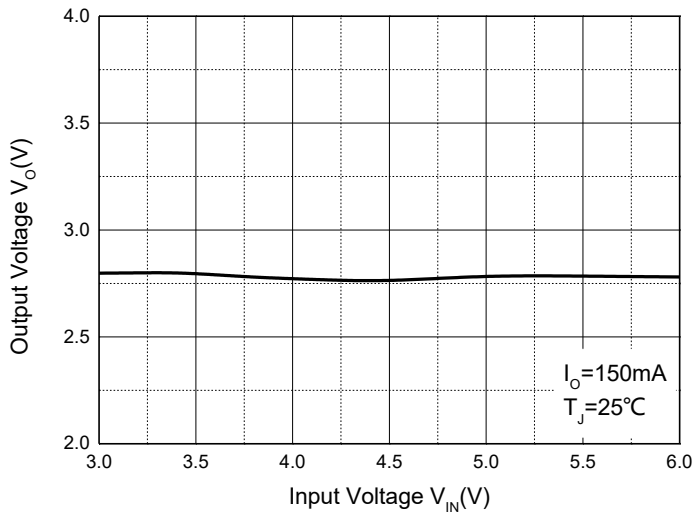

### Output Voltage vs. Temperature

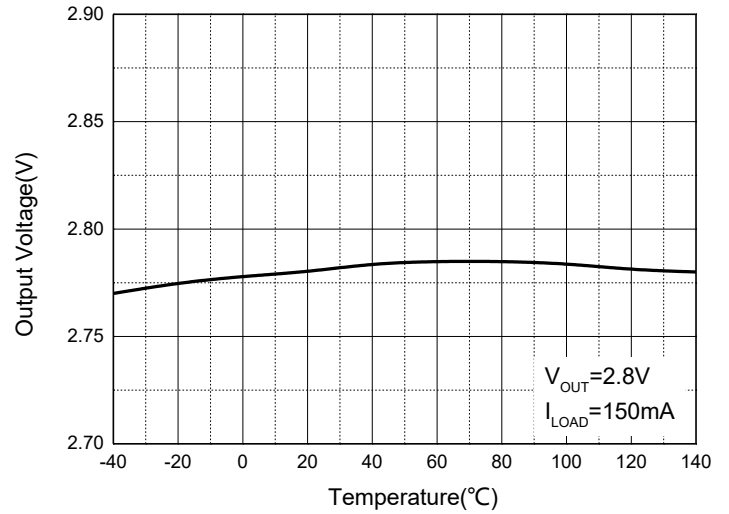

### Quiescent Current

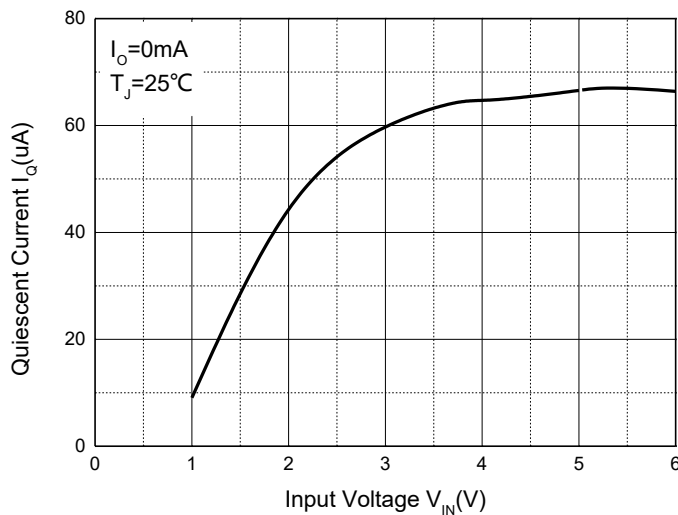

### Current Cut-off Grid Voltage

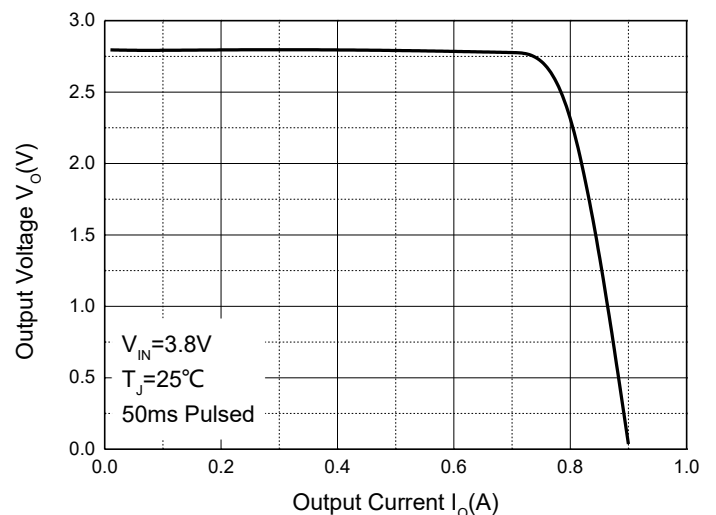

### Dropout Voltage vs. Load Current

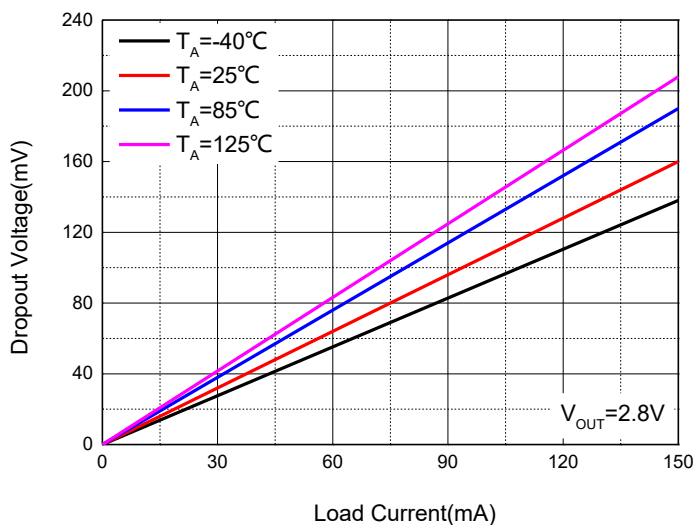

### PSRR vs. Frequency

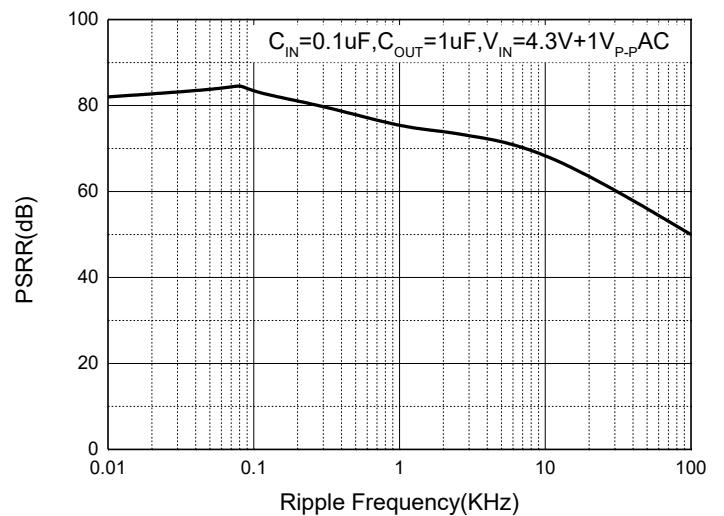

## SOT-23-3L Package Outline Dimensions

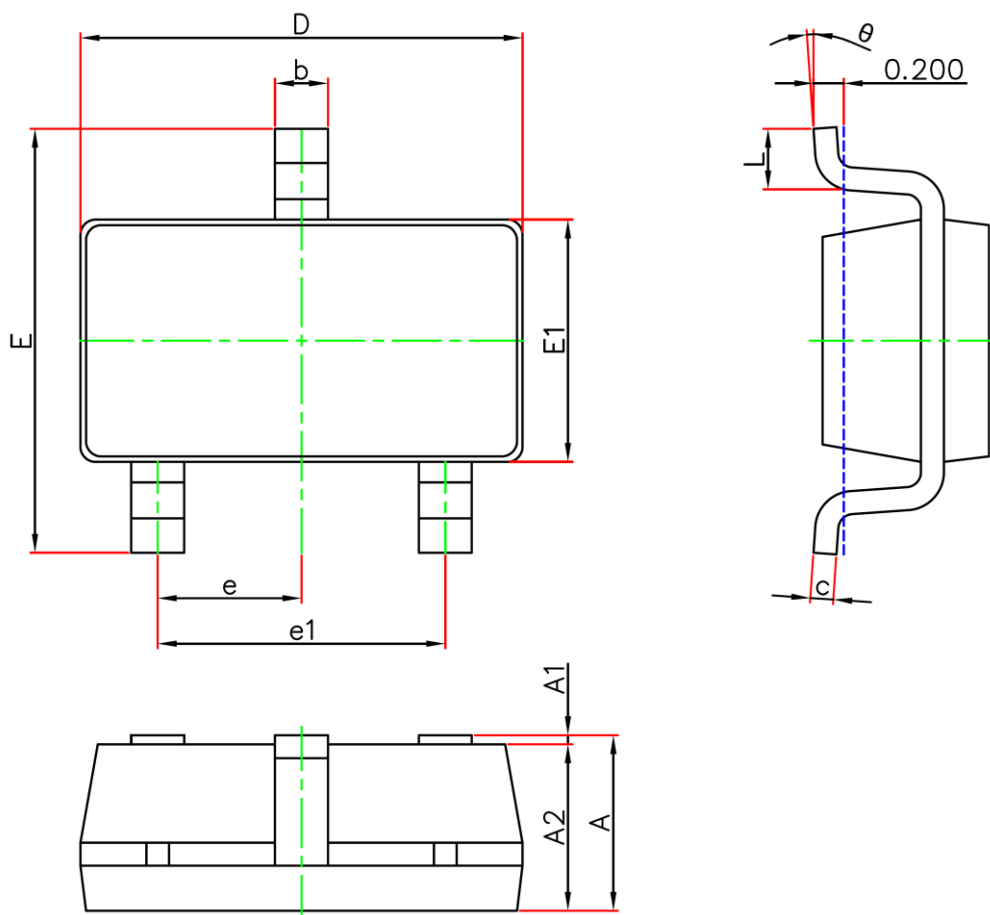

Symbol	Dimensions In Millimeters		Dimensions In Inches	
	Min.	Max.	Min.	Max.
A	1.050	1.250	0.041	0.049
A1	0	0.150	0.000	0.006
A2	1.050	1.250	0.041	0.049
b	0.300	0.500	0.012	0.020
c	0.100	0.200	0.004	0.008
D	2.820	3.020	0.111	0.119
E	2.650	2.950	0.104	0.116
E1	1.500	1.700	0.059	0.067
e	0.950TYP		0.037TYP	
e1	1.800	2.000	0.071	0.079
L	0.300	0.600	0.012	0.024
θ	0°	8°	0°	8°

## SOT-23-5L Package Outline Dimensions

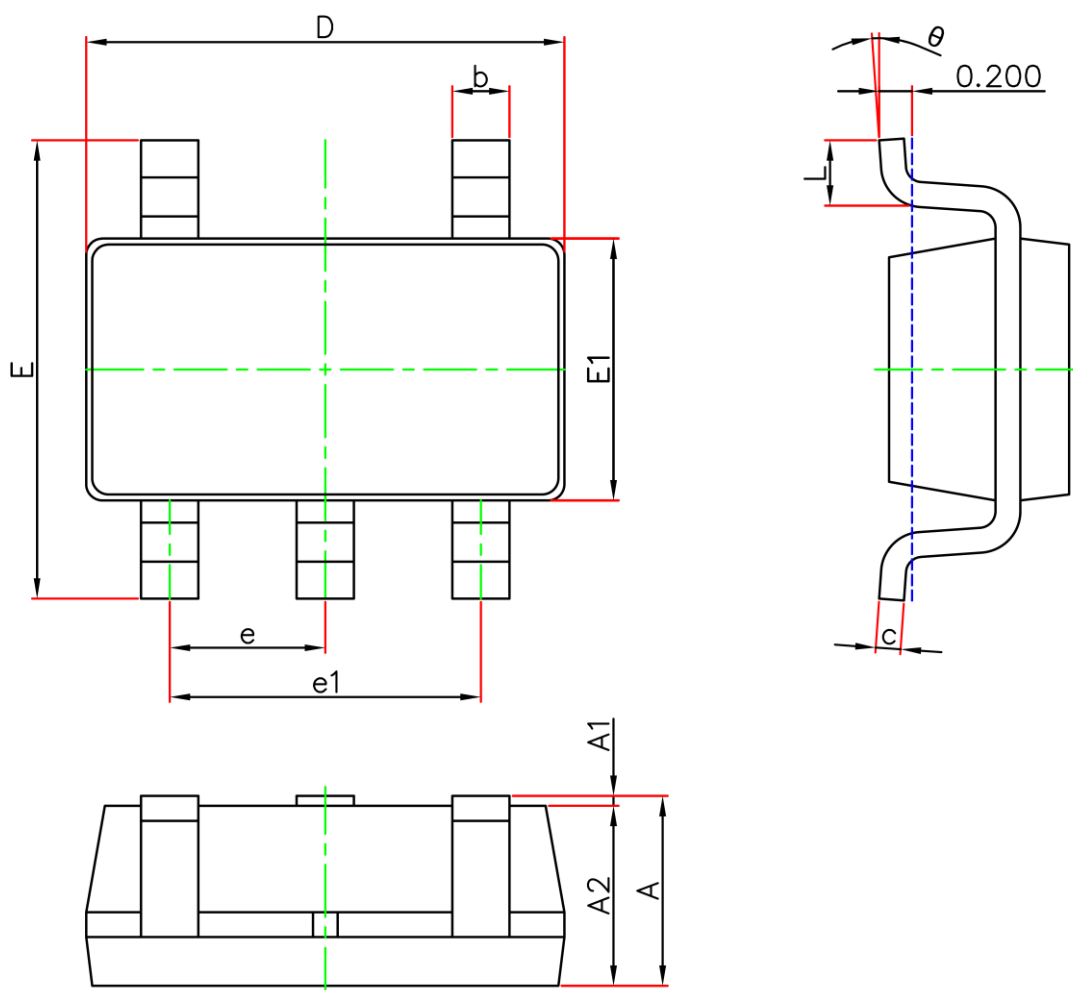

Symbol	Dimensions In Millimeters		Dimensions In Inches	
	Min.	Max.	Min.	Max.
A	1.050	1.250	0.041	0.049
A1	0	0.150	0.000	0.006
A2	1.050	1.250	0.041	0.049
b	0.300	0.500	0.012	0.020
c	0.100	0.200	0.004	0.008
D	2.820	3.020	0.111	0.119
E	2.650	2.950	0.104	0.116
E1	1.500	1.700	0.059	0.067
e	0.950TYP		0.037TYP	
e1	1.800	2.000	0.071	0.079
L	0.300	0.600	0.012	0.024
θ	0°	8°	0°	8°

## DFN1\*1-4L Package Outline Dimensions

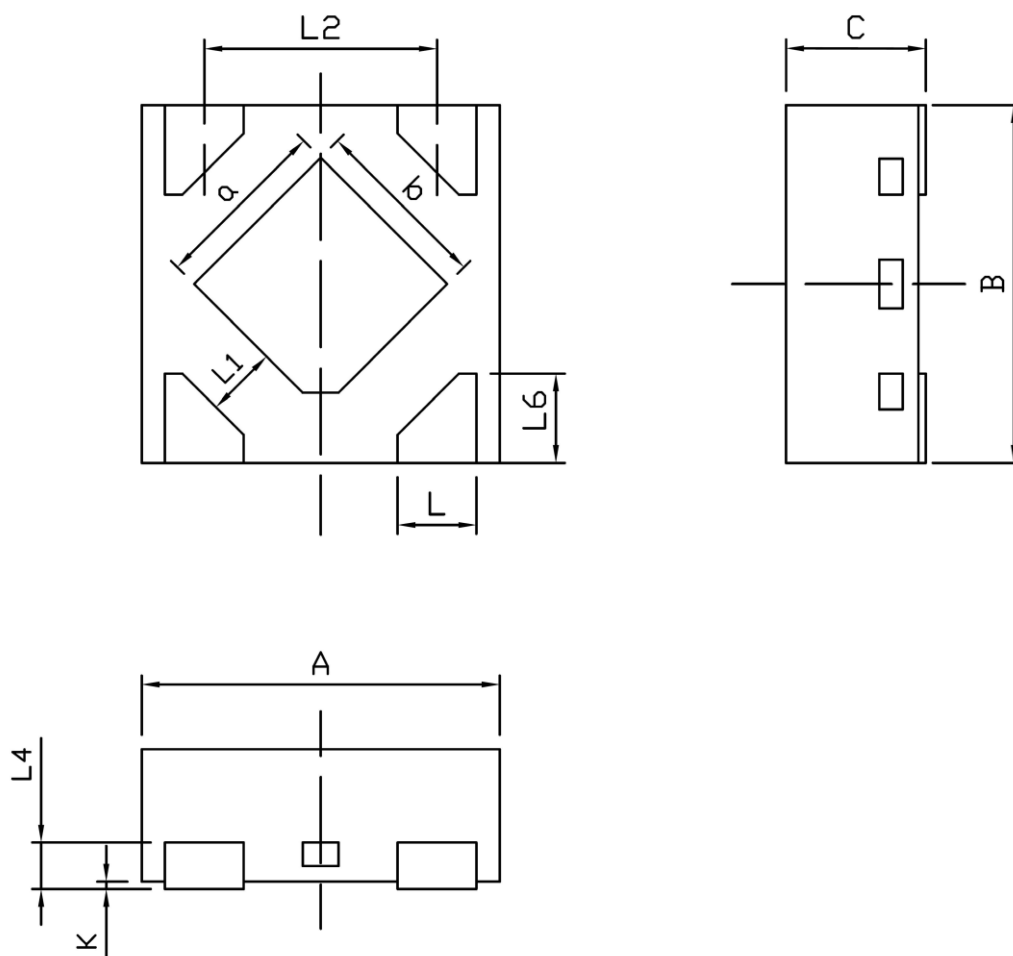

Symbol	Dimensions In Millimeters		Dimensions In Inches	
	Min.	Max.	Min.	Max.
A	0.950	1.050	0.037	0.041
B	0.950	1.050	0.037	0.041
C	0.340	0.400	0.013	0.016
L	0.150	0.250	0.006	0.010
L1	0.150MIN		0.006MIN	
L2	0.650BSC		0.026BSC	
L4	0.127REF		0.005REF	
L6	0.200	0.300	0.008	0.012
K	0.000	0.050	0.000	0.002
a	0.380	0.580	0.015	0.023
b	0.380	0.580	0.015	0.023



## SOT-89-3L Package Outline Dimensions

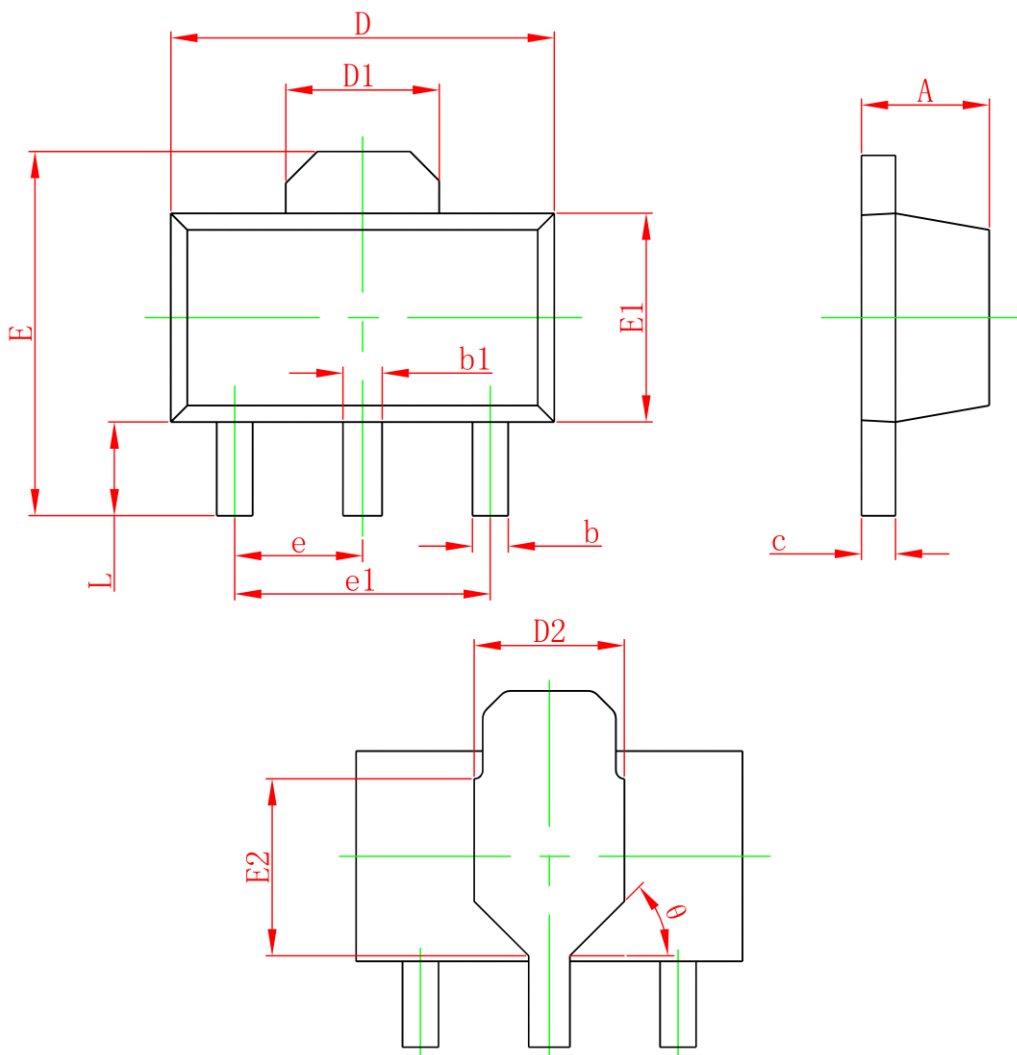

Symbol	Dimensions In Millimeters		Dimensions In Inches	
	Min.	Max.	Min.	Max.
A	1.400	1.600	0.055	0.063
b	0.320	0.520	0.013	0.020
b1	0.380	0.580	0.015	0.023
c	0.350	0.500	0.014	0.020
D	4.400	4.600	0.173	0.181
D1	1.650REF		0.065REF	
D2	1.650	1.850	0.065	0.073
E	3.900	4.400	0.154	0.173
E1	2.300	2.600	0.091	0.102
E2	1.900REF		0.075REF	
e	1.500TYP		0.059TYP	
e1	3.000TYP		0.118TYP	
L	0.900	1.200	0.035	0.047
θ	45°		45°	

## SOT-89-5L Package Outline Dimensions

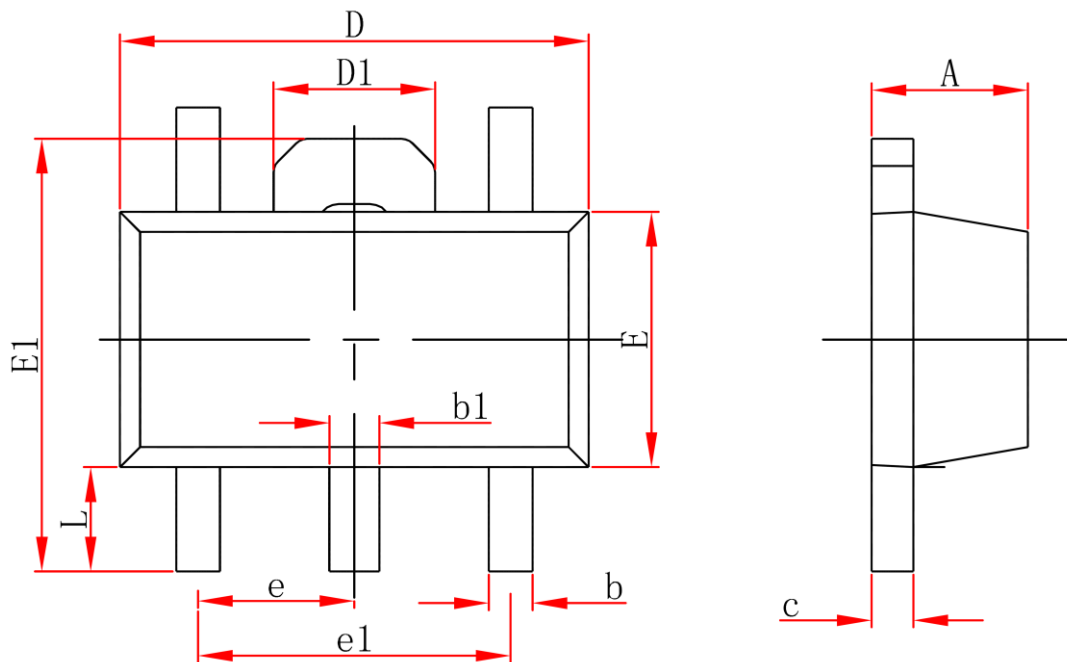

Symbol	Dimensions In Millimeters		Dimensions In Inches	
	Min.	Max.	Min.	Max.
A	1.400	1.600	0.055	0.063
b	0.320	0.520	0.013	0.020
b1	0.380	0.580	0.015	0.023
c	0.350	0.500	0.014	0.020
D	4.400	4.600	0.173	0.181
D1	1.650REF		0.065REF	
E	2.300	2.600	0.091	0.102
E1	3.900	4.400	0.154	0.173
e	1.500TYP		0.059TYP	
e1	3.000TYP		0.118TYP	
L	0.900	1.200	0.035	0.047

## SOT-23-5L Package Outline Dimensions

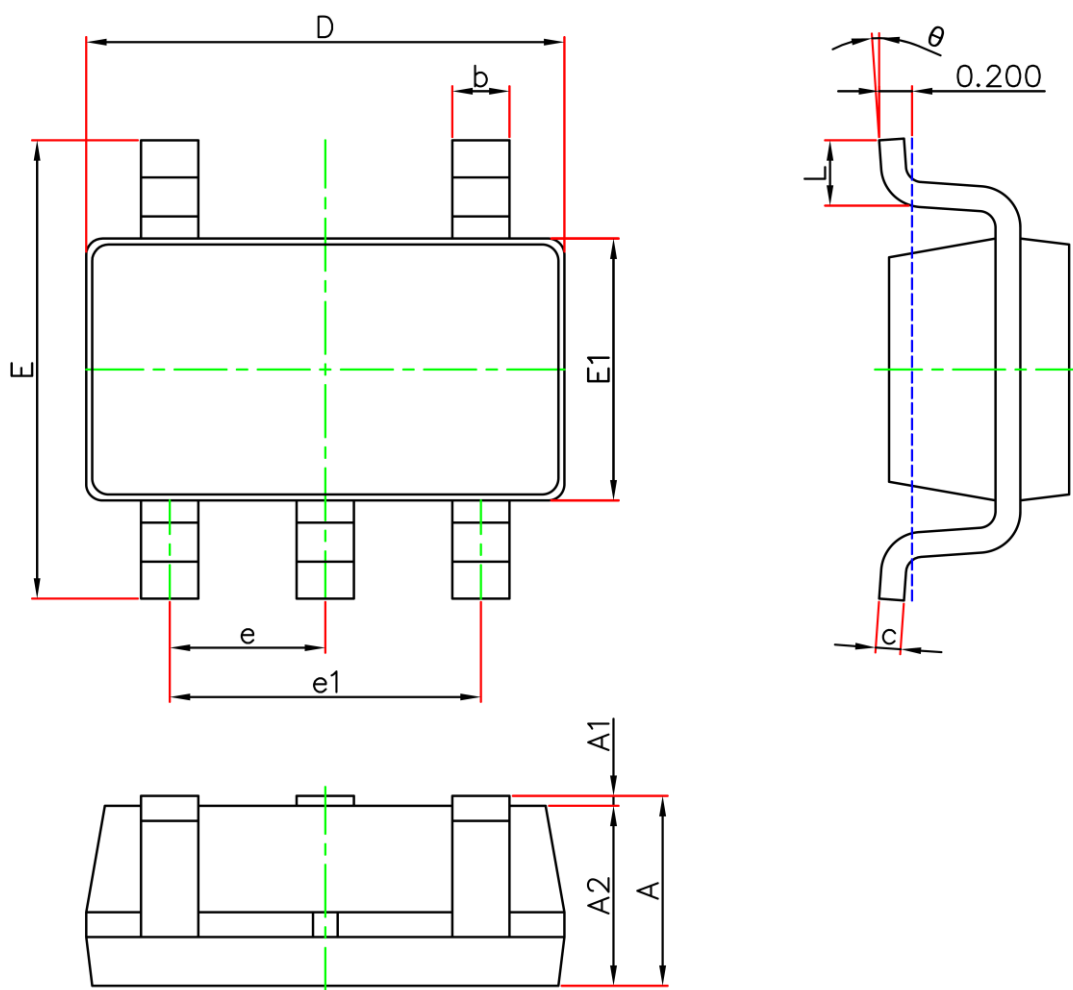

Symbol	Dimensions In Millimeters		Dimensions In Inches	
	Min.	Max.	Min.	Max.
A	1.050	1.250	0.041	0.049
A1	0	0.150	0.000	0.006
A2	1.050	1.250	0.041	0.049
b	0.300	0.500	0.012	0.020
c	0.100	0.200	0.004	0.008
D	2.820	3.020	0.111	0.119
E	2.650	2.950	0.104	0.116
E1	1.500	1.700	0.059	0.067
e	0.950TYP		0.037TYP	
e1	1.800	2.000	0.071	0.079
L	0.300	0.600	0.012	0.024
θ	0°	8°	0°	8°